

Characteristics / Ordering Code

Manatrol needle valve with steel body as screw-in valve for block insertion, optionally with a 30° taper fine V-notch or micro-fine rectangular slot. The form of the metering opening influences the accuracy of the flow adjustment, which is pressure and viscosity dependent. The needle is made of stainless steel and fits into a ring gap in the valve cartridge. For details of cutting tools for reaming the block bore, see 'Accessories' at the end of this chapter.

Characteristic values

Size	Operating press. [bar]	Flow [l/min] Δp 10 bar	Max. orifice area [cm ²]	Kv factor valve	Weight [kg]
400	350	25	0.14	6.3	0.18
600	350	65	0.37	18.5	0.32
800	350	105	0.55	27.5	0.59
1200	350	160	0.90	45.7	0.95
Needle size					
400-2		11	0.52		
400-3		2	0.012		

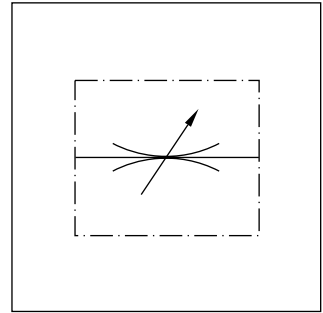
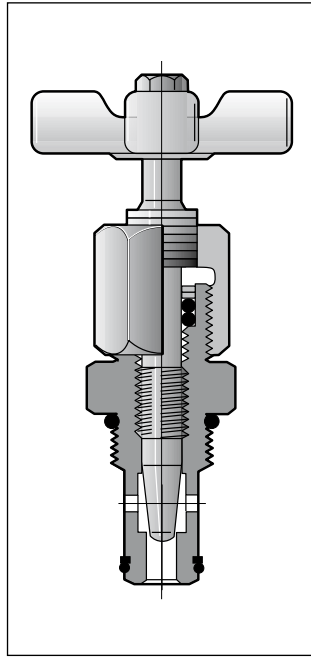

5

Flow rate Q [l/min] = Kv · $\sqrt{\frac{\Delta p}{\gamma}}$

Kv see table
 Δp [bar]
 γ [kg/dm³] = specific gravity of fluid
 (γ for mineral oil = 0.85 – 0.9)

Δp/Q curves

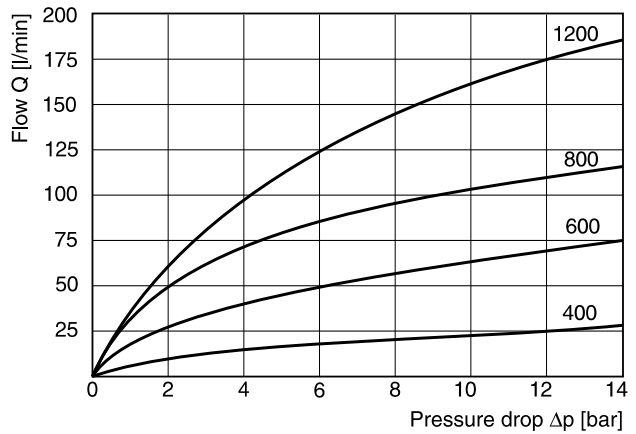

All characteristic curves measured with HLP46 at 50 °C.

Ordering code

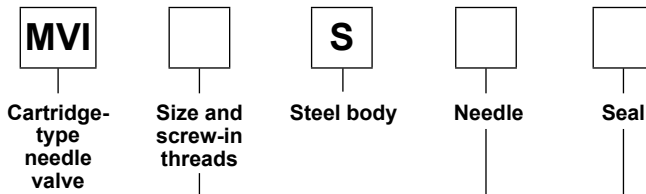

Code	Size	Threads
400	1/4"	3/4 - 16 UNF-2B
600	3/8"	7/8 -14 UNF-2B
800	1/2"	1 1/16 - 12 UN-2B
1200	3/4"	1 5/16 - 12 UN-2B

Code	Seal
omit	NBR
V	FPM

Code	Needle
omit	Standard 30° taper
2 ¹⁾	Fine V-notch
3 ¹⁾	Micro-fine slotted

Bold letters = Short-term availability

¹⁾ Only for size 400.

Threaded cartridge valve

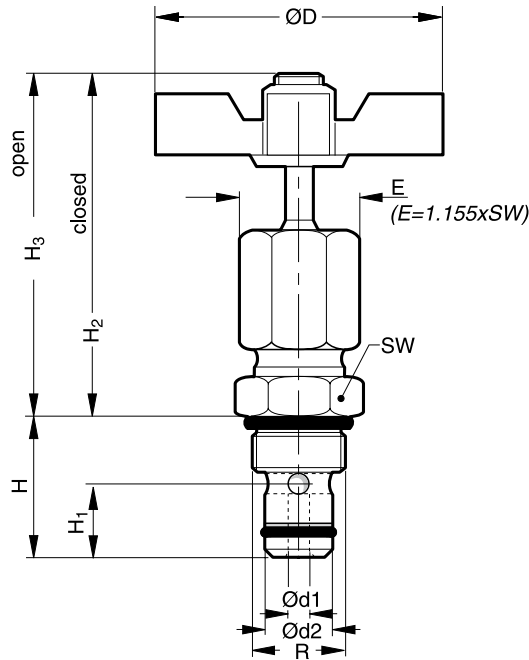

5

Size	H	H ₃	H ₂	H ₁	Ød ₁	Ød ₂	R (Threads)	ØD	SW
MVI 400	25.4	65	60	10.9	4.6	14.22	3/4 - 16 UNF-2	51	22.1
MVI 600	30	81	73	13.5	7.9	15.8	7/8 - 14 UNF-2	64	25.4
MVI 800	39.6	91	79	15.2	9.4	20.55	1 1/16 - 12 UN-2	83	31.8
MVI 1200	43.4	102	88	19.1	11.7	26.92	1 5/16 - 12 UN-2	98	38.1

Mounting cavity

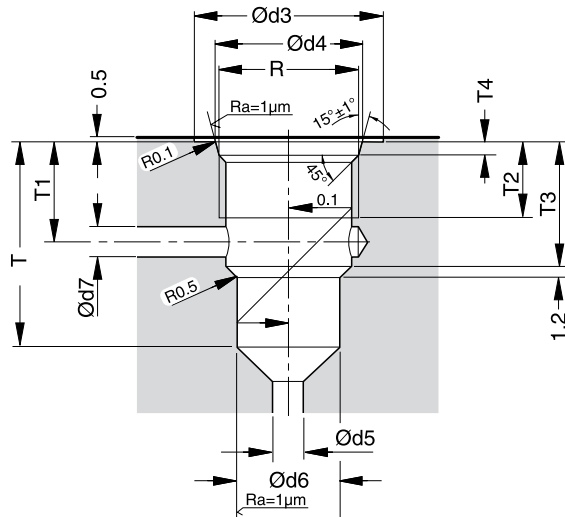

Size	Ød ₃	Ød ₄ ^{+0.12}	Ød ₅ (min)	Ød ₆ ^{+0.05}	Ød ₇	T ₄ ^{+0.38}	T ₂	T ₃	T	T ₁
MVI 400	26	20.6	5.3	14.275	5.3	2.54	15	17.8	27	14.2
MVI 600	30	23.93	8.1	15.85	8.1	2.54	17	21.6	32	16.5
MVI 800	37	29.16	10.2	20.6	10.2	3.3	19	30	42	24.1
MVI 1200	44	35.54	12.7	26.975	12.7	3.3	19	31.8	46	24.6